



LUMIX PROCUT
Food Processing Solutions



Scies à os

SX300 - SX350



Scies à gros débit
Entièrement inox 18/10
Nettoyage très facile
Grande capacité

Dadaux
TECHNOLOGIES



SX350
SX350S



SX300
SX300S

Qualité
100%
INOX



SCIES À OS Sx300 - Sx350

Entièrement Inox. Bâti forte épaisseur parfaitement rigide. Tendeur automatique de lame. Guide lame supérieur coulissant avec maintien en position automatique. Très facile à entretenir. Chariot coulissant pour les scies SX300 et SX350 pour une accessibilité parfaite pour le nettoyage. Moteur et matériel électrique protégés contre les projections d'eau. Conformés aux normes CE. Certifiée Adiva.

Band saw SX

Entirely stainless steel 18-10. Frame strong thickness perfectly rigid. Automatic blade stretcher. Sliding upper blade guide keeping in automatic position. Very easy to maintain. Moving carriage for SX300 and SX350 for a perfect accessibility for the cleaning. Motor and electrical components protected against water splash. Complies CE norms. Certified Adiva.

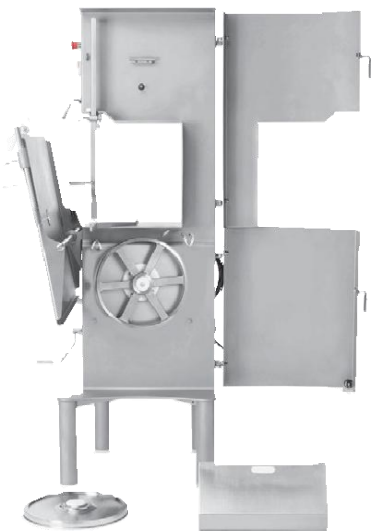

SX350 en position de nettoyage
SX350 in cleaning position

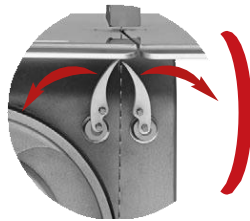

Racleur monté sur ressort pour garantir l'efficacité, et escamotable pour faciliter la mise en place de la lame et le nettoyage.

Scrapers on springs to ensure the effectiveness and lift off to facilitate the establishment of the blade and the clearing.



Poulie inférieure
Lower wheels

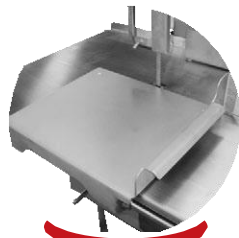

Chariot coulissant pour SX300 et SX350
Moving carriage for SX300 and SX350

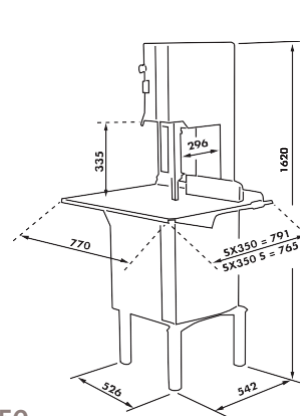

SX350 - SX350 S

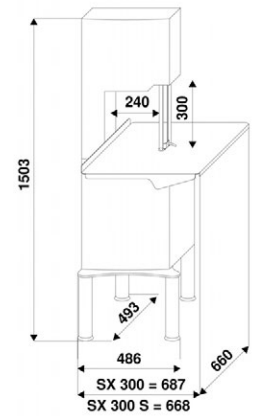

SX300 - SX300 S

Réf Ref	Type de table Table type	Tension Tension	Capacité coupe Cutting capacity	Dimensions lame Blade dimensions	Moteur Motor	Vitesse lame Speed blade	Poids net Weight
SX300S	Poussoir articulé	TRI, 400V, 50 HZ	240 x 300 mm	2170 x 16	2 CV (1,5 Kw)	20 m / s	125 Kg
SX300	Plateau coulissant	TRI, 400V, 50 HZ	240 x 300 mm	2170 x 16	2 CV (1,5 Kw)	20 m / s	120 Kg
SX350S	Poussoir articulé	TRI, 400V, 50 HZ	300 x 340 mm	2490 x 16	2,5 CV (1,84 Kw)	23 m / s	145 Kg
SX350	Plateau coulissant	TRI, 400V, 50 HZ	300 x 340 mm	2490 x 16	2,5 CV (1,84 Kw)	23 m / s	140 Kg

Poussoir articulé - Articulated push / Plateau coulissant - Moving carriage