



**LUMIX PROCUT**  
Food Processing Solutions



*Scies à os*

# SX400 - SX400S



Scies à gros débit  
Entièrement inox 18/10  
Nettoyage très facile  
Grande capacité

**Dadaux**  
TECHNOLOGIES

Qualité  
100%  
INOX



SX400 en position  
de nettoyage  
SX400 in cleaning position

## SCIES À OS Sx400 - Sx400S

Entièrement Inox. Bâti forte épaisseur parfaitement rigide. Tendeur automatique de lame. Guide lame supérieur coulissant avec maintien en position automatique. Chariot coulissant pour la scie SX400. Très facile à entretenir. Moteur et matériel électrique protégés contre les projections d'eau. Conformés aux normes CE. Certifiée Adiva.



### Band saw SX400 - SX400S

Entirely stainless steel 18-10. Frame strong thickness perfectly rigid. Automatic blade stretcher. Sliding upper blade guide keeping in automatic position. Moving carriage for SX400. Very easy to maintain. Motor and electrical components protected against water splash. Complies CE norms. Certified Adiva.



Poulie inférieure  
Lower wheels



Racleur monté sur ressort pour garantir l'efficacité, et escamotable pour faciliter la mise en place de la lame et le nettoyage.

Scrapers on springs to ensure the effectiveness and lift off to facilitate the establishment of the blade and the cleaning.

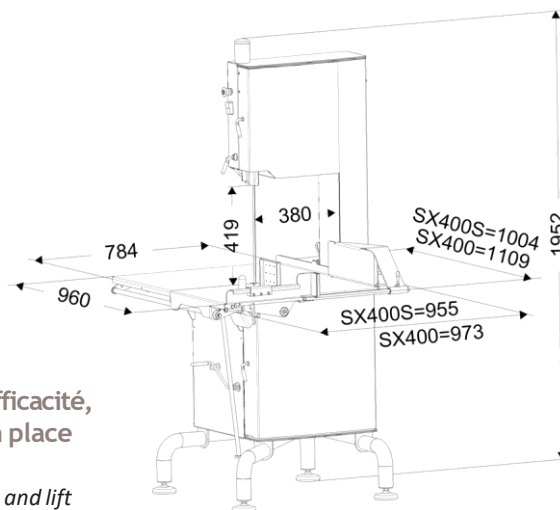

SX400 - SX400 S

Réf Ref	Type de table Table type	Tension Tension	Capacité coupe Cutting capacity	Dimensions lame Blade dimensions	Moteur Motor	Vitesse lame Speed blade	Poids net Weight
SX400S	Poussoir articulé	TRI, 400V, 50 HZ	419 x 380 mm	3150 x 16	4 CV (3 Kw)	29 m / s	265 Kg
SX400	Plateau coulissant	TRI, 400V, 50 HZ	419 x 380 mm	3150 x 16	4 CV (3 Kw)	29 m / s	265 Kg

Poussoir articulé - Articulated push / Plateau coulissant - Moving carriage