



LUMIX PROCUT
Food Processing Solutions



Scies à os

SX200 - SX220



Scies à gros débit
Entièrement inox 18/10
Nettoyage très facile
Grande capacité

Dadaux
TECHNOLOGIES



SX220
Position nettoyage - Plateau basculant
Cleaning position - Tip table



SX220
Porte arrière étanche avec joint silicone
Silicone water tight joint on back door



SX200

Tendeur automatique de la lame
Blade automatic stretcher



Poulie
Wheels

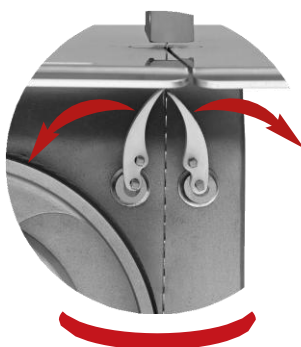

Racleur monté sur ressort pour garantir l'efficacité, et escamotable pour faciliter la mise
Scrapers on springers to ensure the effectiveness and lift off to facilitate the establishment of the blade and the cleaning.

Éléments manœuvre entièrement Inox
Entirely stainless steel handle

SCIES À OS SX200 & SX220

Entièrement Inox. Bâti forte épaisseur parfaitement rigide. Tendeur automatique de lame. Guide lame supérieur coulissant avec maintien en position automatique. Très facile à entretenir. Table basculante pour la scie SX220 pour une accessibilité parfaite pour le nettoyage. Moteur et matériel électrique protégés contre les projections d'eau. Conformés aux normes CE. Certifiée Adiva.

Band saw SX200 and SX220

Entirely stainless steel 18-10. Frame strong thickness perfectly rigid. Automatic blade stretcher. Sliding upper blade guide keeping in automatic position. Very easy to maintain. Tipping table for the saw SX220 for a perfect accessibility for the cleaning. Motor and electrical components protected against water splash. Complies CE norms. Certified Adiva.

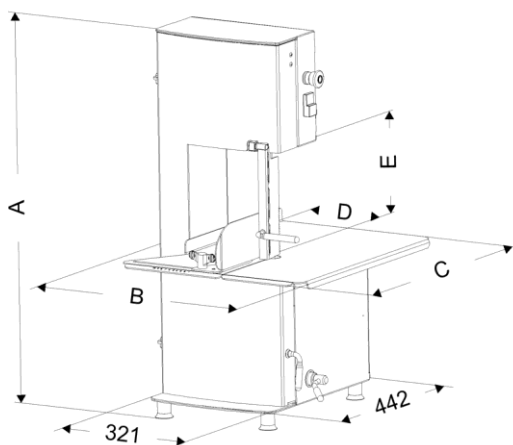

Dimensions
Dimensions

	SX200	SX220
A	874	921
B	510	529
C	571	558
D	188	194
E	245	230

Réf Ref	Motor Motor	Capacité coupe Cutting capacity	Dim. Machine Machine dimension	Dim. lame Blade dimensions	Vitesse lame Blade speed	Poids net Weight	
SX200	1 CV (0,75 Kw)	L 190 x H 245 mm	489 x 571 x 874 mm Avec socle : 489 x 571 x 1350 mm	1640 x 16 mm	15 m/s	52 kg 72 kg avec socle	Poussoir articulé Articulated push
SX220	1,5 CV (1,1 Kw)	L 200 x H 230 mm	508 x 638 x 922 mm Avec socle : 508 x 638 x 1400 mm	1740 x 16mm	17 m/s	70 kg 90 kg avec socle	Poussoir articulé Articulated push



LUMIX PROCUT
Food Processing Solutions